

Moulinex®

uno

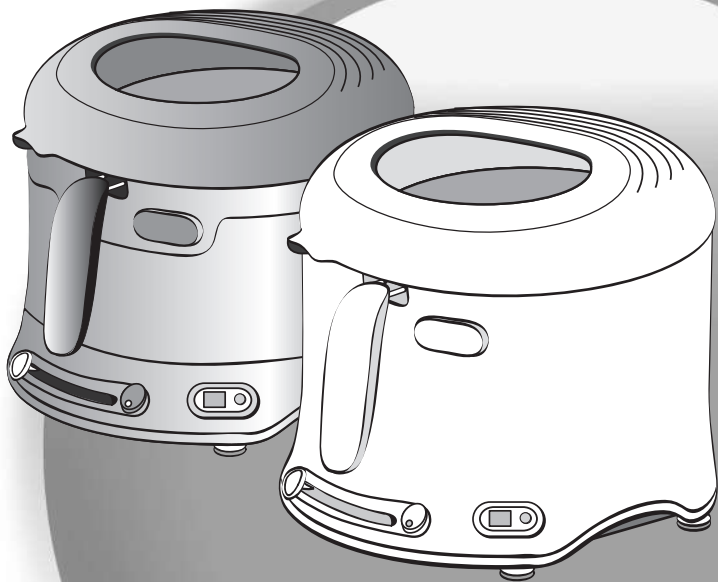

www.moulinex.com

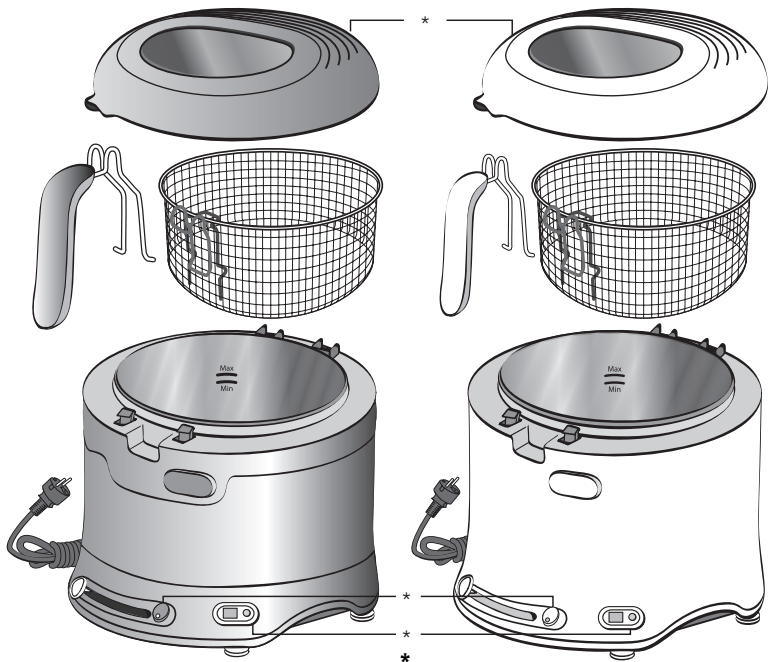

*selon modèle • depending on model • je nach Modell • a seconda del modello • según modelo • consoante os modelos • Ανάλογα με το μοντέλο • В зависимости от модели • Залежно від моделі • zależnie od modelu • az egyes modellek szerint • podle modelů • podľa modelov • В зависимости от модели • În funcție de model • modellere göre • Зависно од модела • zavisno od modela • Ölede na model • بر حسب مدل • بحسب الموديل

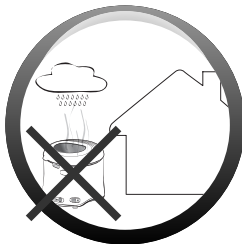

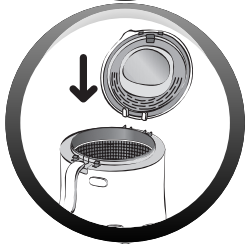
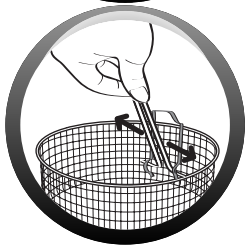
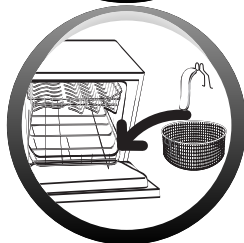
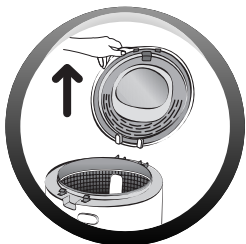



Min 1,6 L
Max 1,8 L

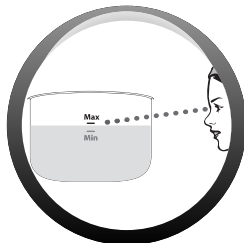

Min 1400 g
Max 1600 g

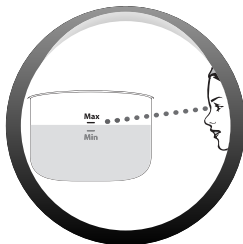
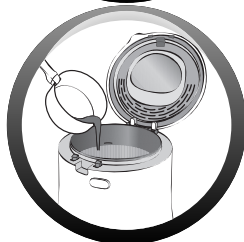



Max 800 g



500 g

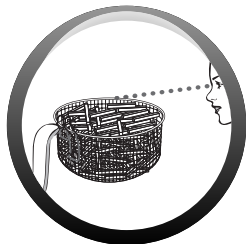

Max 750 g





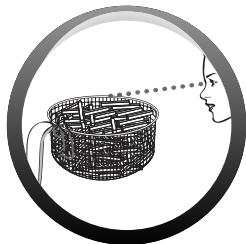

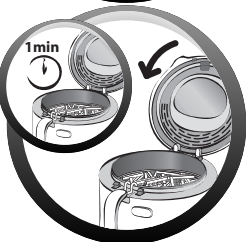
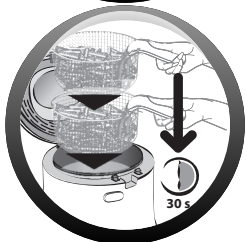
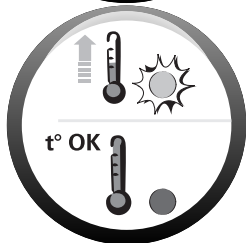
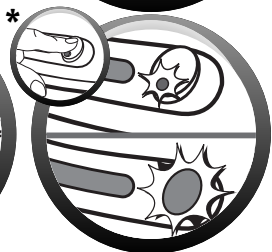
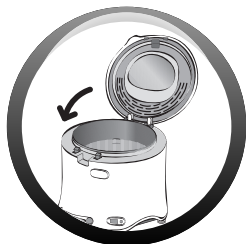
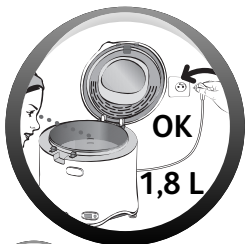

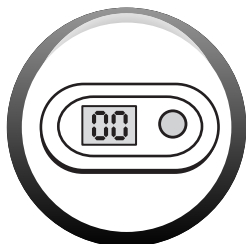
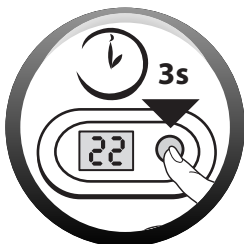
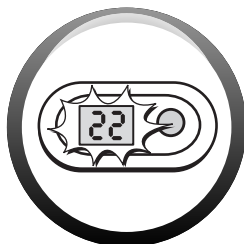
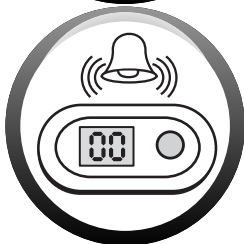
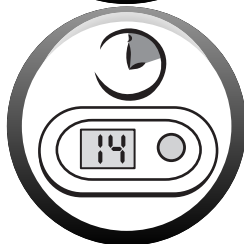
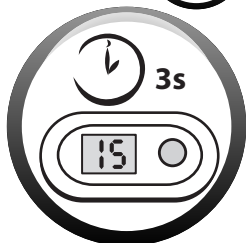

















380 g









	Nb		°C	
		800 g	1) 160°C	7-8 min.
			2) 190°C	5-6 min.
		800 g	190°C	11-14 min.
		500 g	190°C	9-11 min.
		3-4	180°C	15-20 min.
		2	160°C	6-8 min.
		8	150°C	6-8 min.
		10-12	180°C	6-7 min.
		500 g	180°C	4-5 min.
		4	170°C	7-8 min.
* * *	Nb		°C	
		750 g	190°C	12-14 min.
		380 g	190°C	6-7 min.
		3-4	190°C	18-20 min.
		2	190°C	6-8 min.
		22 g	190°C	4-5 min.
		1 Kg	190°C	8-9 min.
		5	190°C	4-5 min.

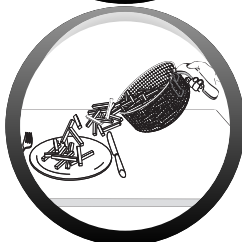
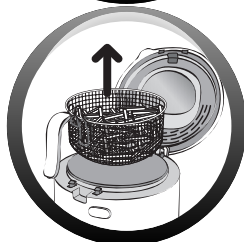
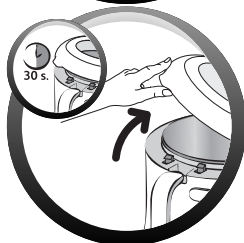
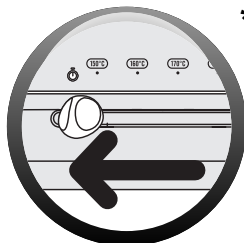

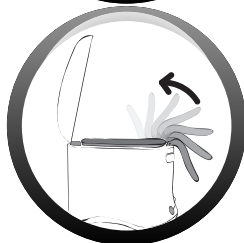
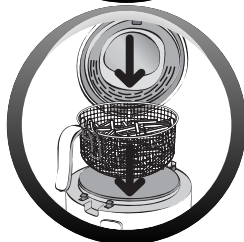
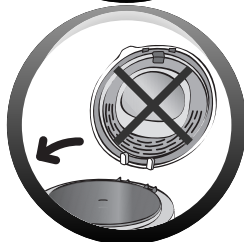
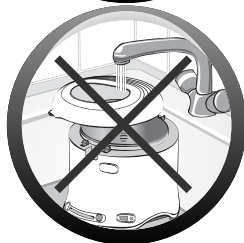
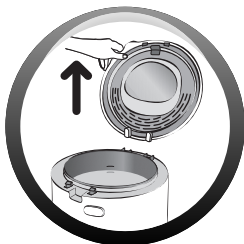



Moulinex®
UNO

Ref. NC00026762

www.moulinex.com